



James Turcio
Building Official

CITY OF NEW HAVEN

Toni N. Harp., Mayor

BUILDING DEPARTMENT

200 Orange Street 5th Floor

New Haven, CT 06510

Phone: (203) 946-8045 Fax: (203) 946-8049



Tony Harp
Mayor

WOOD CONSTRUCTED DECK HANDOUT

Keep this handout with plans on site

Complete My Deck

Address: _____ New Haven, CT.

Prior to construction, design the specifics of your deck and complete the information required below. This information shall be available to the inspector at each inspection.

1. On the next page of this sheet sketch your deck. Ensure beam and post locations and corresponding dimensions are shown. Show your deck's overall length and width and any other necessary dimensions.
2. Complete the design details of your deck below.

DECKING: size: 2x4/2x6 five-quarter board direction: angled perpendicular

material: preservative-treated lumber plastic composite non-native lumber PVC

JOIST 1: size: 2x6 2x8 2x10 2x12 spacing: 12 in. 16 in. 24 in.

longest span: ___ ft. - ___ in. overhang: ___ ft. - ___ in.

rim joist: 2x6 2x8 2x10 2x12 not applicable

JOIST 2: size: 2x6 2x8 2x10 2x12 spacing: 12 in. 16 in. 24 in.

longest span: ___ ft. - ___ in. overhang: ___ ft. - ___ in.

rim joist: 2x6 2x8 2x10 2x12 not applicable

BEAM 1: plies: 2 3 size: 2x6 2x8 2x10 2x12

influence width: ___ ft. - ___ in. longest span: ___ ft. - ___ in. overhang: ___ ft. - ___ in.

footing size: ___ in. square round thickness: ___ in.

post size: 4x4 6x6 post height: ___ ft. - ___ in.

BEAM 2: plies: 2 3 size: 2x6 2x8 2x10 2x12

influence width: ___ ft. - ___ in. longest span: ___ ft. - ___ in. overhang: ___ ft. - ___ in.

footing size: ___ in. square round thickness: ___ in.

post size: 4x4 6x6 post height: ___ ft. - ___ in.

LEDGER BOARD: size: 2x8 2x10 2x12 not applicable (free-standing deck)

fastener: through-bolt lag screw expansion anchor adhesive anchor wood screw

spacing: ___ in.

LATERAL SUPPORT (check all that apply):

- METHOD 1 - TENSION TIES
- METHOD 2 - ANGLE BACES
- METHOD 3 - FREE STANDING DECK ONLY

Plan

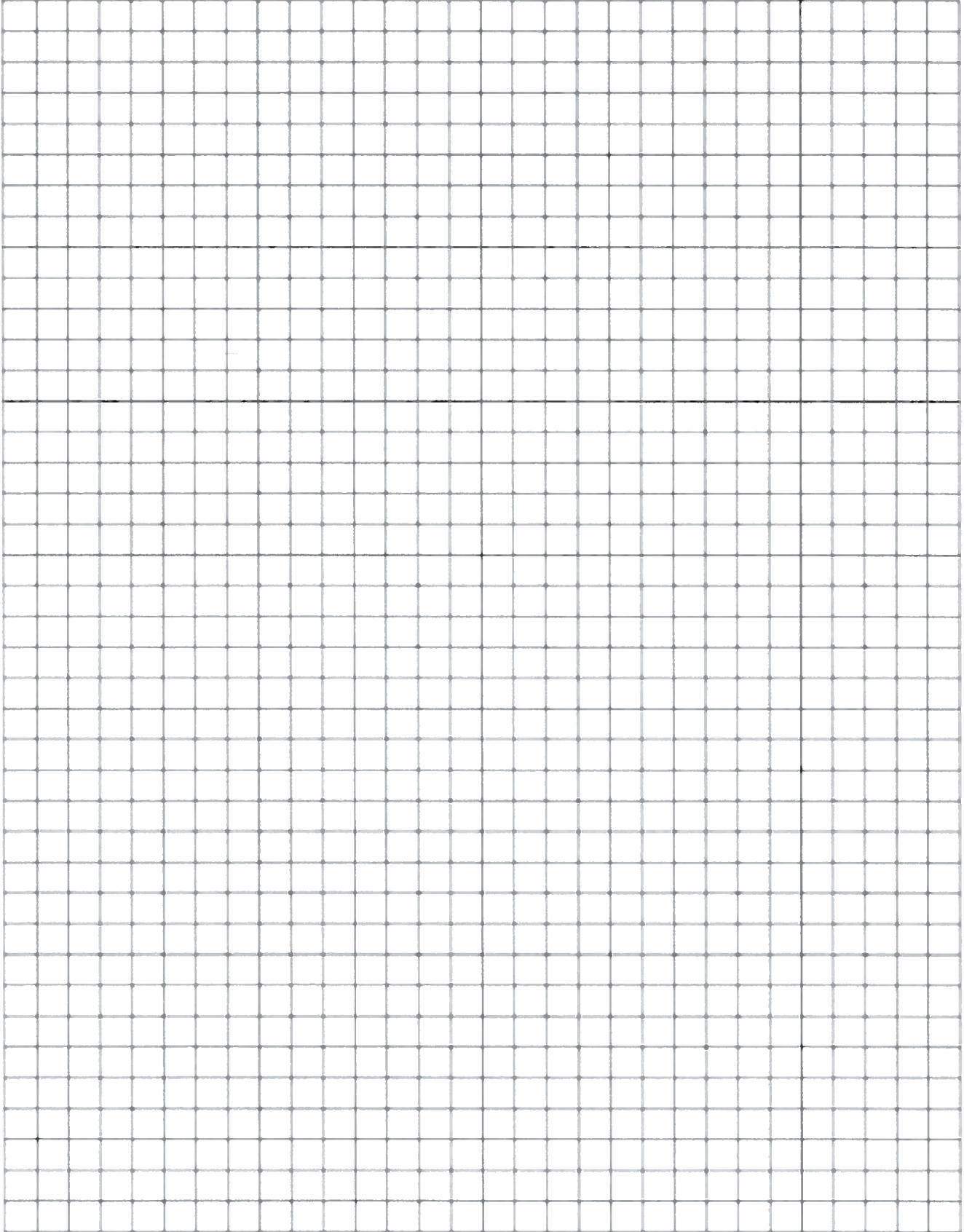

Deck Guidelines

FLOOR PLAN

1. Proposed Deck Size
2. Size and spacing of floor joists
3. Size and Type of decking material
4. Size, type, location, and spacing of posts.
5. Size and type of beams

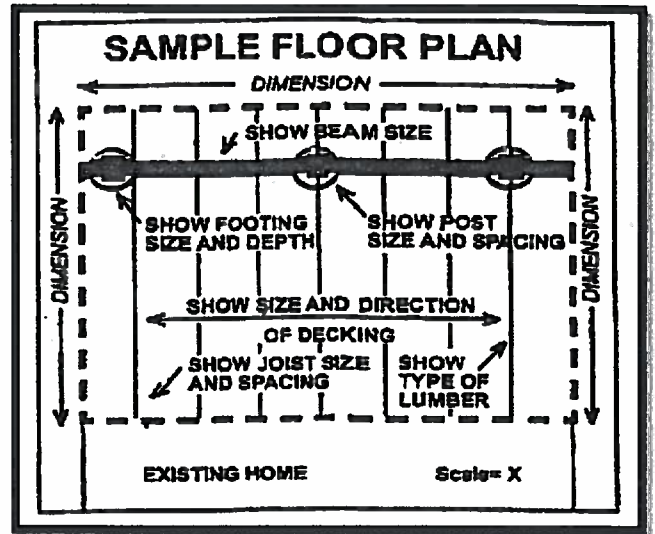

ELEVATION PLAN

1. Height of Structure from grade.
2. Size and depth of footings
3. Guard height and spacing (if any)
4. Stairway rise/run and handrail height (if any)
5. Clearance of over-head wires (if any)
6. Ledger attachment details and flashing information

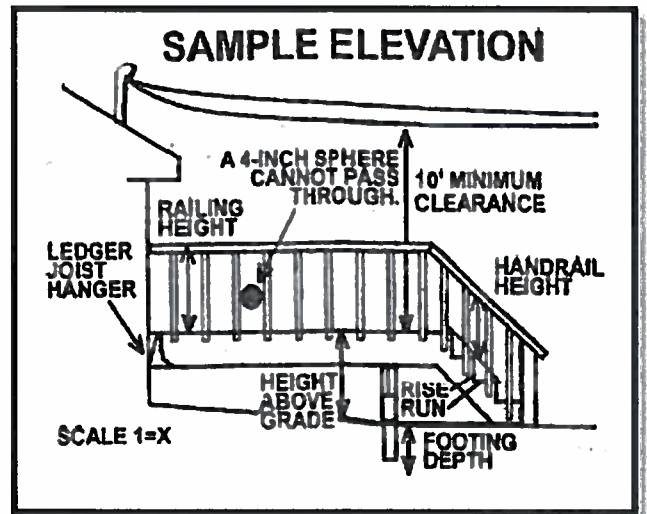

Wood Constructed Decks

This is only a guide, not an instruction form

The floor-loading requirement of the Connecticut State Building Code is 40 lbs. per square foot live load. If you are using pressure treated #2 southern yellow pine for joists, the maximum clear span for a particular size and center spacing is as follows:

12" on Center		16" on Center		24" on Center	
2 X 6	9' - 11"	2 X 6	9'	2 X 6	7' - 7"
2 X 8	13' - 1"	2 X 8	11' - 10"	2 X 8	9' - 8"
2 X 10	16' - 2"	2 X 10	14'	2 X 10	11' - 5"
2 X 12	18' - 0"	2 X 12	16' - 16"	2 X 12	13' - 6"

If a minimum 2" bearing of joists ends is not provided, proper sized joist hangers shall be installed and fastened per manufacturer's installation instructions. Sheet rock screws, deck screws or similar are not approved fasteners. All metal fasteners and connectors must be hot dipped galvanized or equivalent.

The maximum amount of cantilever allowed is as follow: (3:1 backspan ratio)

12" on Center		16" on Center		24" on Center	
2 X 8	1' - 10"	2 X 8	2'		
2 X 10	3' - 11"	2 X 10	3' - 5"	2 X 10	2' - 4"
		2 X 12	4' - 12"	2 X 12	2' - 10"

Flashing is required where deck is joined to building. A single ledger or rim joist against the building must be positively attached to the primary structure and designed for both vertical and lateral loads as applicable. Use lag bolts or other appropriate fasteners as approved to support the loads intended. Where positive attachment to the primary structure cannot be verified during inspection, decks shall be self-supporting.

Girders or outer rim joists must be adequately sized with the proper number of piers. Pier bottoms must be 42" below grade and bear on suitable soil, see page 7.

For decks for 1 and 2 family homes, a 36" guardrail with members that prevent the passage of 4" diameter sphere is required where the floor surface of the deck is more than 30" above the grade or surface below. On the open sides of the stairs with a total rise of more than 30" above the surface or grade below, a 36" high guard is also required. Stairs must have a minimum wide of 36". Stairs require a handrail on one side of the stairs at a height of 34" to 38" measured vertically from the nosing of each tread.

Footings

Table 1. Footing Sizes

Beam Span, L_B	Joist Span, L_J	Round Footing Diameter	Square Footing Dimension	Footing Thickness ²
6'	$\leq 10'$	15"	13"	6"
	$\leq 14'$	17"	15"	6"
	$\leq 18'$	20"	18"	7"
8'	$\leq 10'$	17"	15"	6"
	$\leq 14'$	20"	18"	8"
	$\leq 18'$	23"	21"	9"
10'	$\leq 10'$	19"	17"	7"
	$\leq 14'$	22"	20"	9"
	$\leq 18'$	25"	23"	10"
12'	$\leq 10'$	21"	19"	8"
	$\leq 14'$	24"	22"	10"
	$\leq 18'$	28"	26"	11"
14'	$\leq 10'$	22"	20"	9"
	$\leq 14'$	26"	24"	11"
	$\leq 18'$	30"	28"	12"
16'	$\leq 10'$	24"	22"	9"
	$\leq 14'$	28"	26"	12"
	$\leq 18'$	32"	30"	13"
18'	$\leq 10'$	23"	23"	10"
	$\leq 14'$	28"	28"	12"
	$\leq 18'$	32"	32"	14"

1. Assumes 1,500 psf soil bearing capacity.
 2. Assumes 2,500 psi compressive strength of concrete. Coordinate footing thickness with post base and anchor requirements

See **Figure 1** and **Table 1** for footing size, footing thickness, and post attachment options and requirements. All footings shall bear on solid ground and shall be placed at least 42 inches below the undisturbed ground surface. Bearing conditions shall be verified in the field by the Building Official.

DECK FOOTINGS CLOSER THAN 5'-0" TO AN EXISTING EXTERIOR HOUSE WALL MUST BEAR AT THE SAME ELEVATION AS THE FOOTING OF THE EXISTING HOUSE FOUNDATION.

Do not construct footings over utility lines. Contact local utilities (call 811) before digging.

Pre-manufactured post anchors shall be galvanized. See MINIMUM REQUIREMENTS.

Figure 1. Typical Footing Options

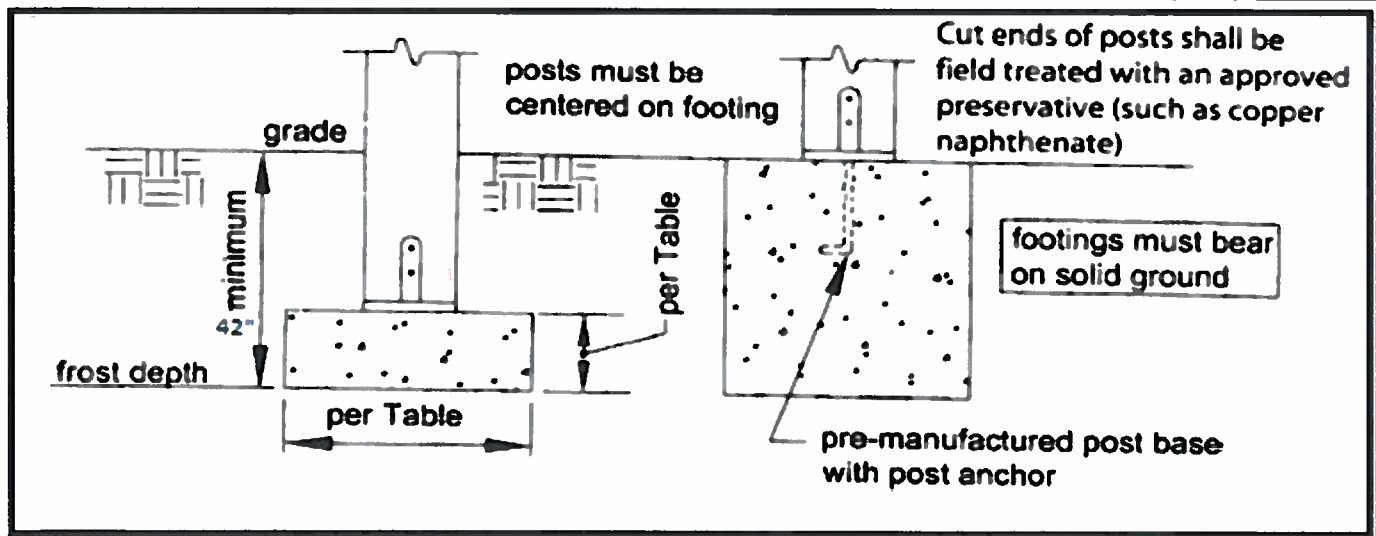

Beam Size & Assembly Requirements

Deck Beam spans shall be in accordance with Table 2 and can extend past the post centerline up to $L_B/4$ as shown in Figure 2.

Table 2. Deck Beam Spans

Dimension Lumber Deck beam Spans (L_B) ¹ for Joists Framing from One Side Only								
Joist Spans (L) Less Than or Equal to:								
Species	Size ⁴	6'	8'	10'	12'	14'	16'	18'
Southern Pine	2-2x6	6' - 8"	5' - 8"	5' - 1"	4' - 7"	4' - 3"	4' - 0"	3' - 9"
	2-2x8	8' - 6"	7' - 4"	6' - 6"	5' - 11"	5' - 6"	5' - 1"	4' - 9"
	2-2x10	10' - 1"	8' - 9"	7' - 9"	7' - 1"	6' - 6"	6' - 1"	5' - 9"
	2-2x12	11' - 11"	10' - 4"	9' - 2"	8' - 4"	7' - 9"	7' - 3"	6' - 9"
	3-2x6	7' - 11"	7' - 2"	6' - 5"	5' - 10"	5' - 5"	5' - 0"	4' - 9"
	3-2x8	10' - 7"	9' - 3"	8' - 3"	7' - 6"	6' - 11"	6' - 5"	6' - 1"
	3-2x10	12' - 9"	11' - 0"	9' - 9"	8' - 9"	8' - 3"	7' - 8"	7' - 3"
	3-2x12	15' - 0"	13' - 0"	11' - 7"	10' - 6"	9' - 9"	9' - 1"	8' - 7"
Douglas Fir-Larch ² , HemFir ² , Spruce-Pine-Fir ² , Redwood, Western Cedars, Ponderosa Pine ³ , Red Pine ³	3x6 or 2-2x6	5' - 2"	4' - 5"	3' - 11"	3' - 7"	3' - 3"	2' - 10"	2' - 6"
	3x8 or 2-2x8	6' - 7"	5' - 8"	5' - 1"	4' - 7"	4' - 3"	3' - 10"	3' - 5"
	3x10 or 2-2x10	8' - 1"	7' - 0"	6' - 3"	5' - 8"	5' - 3"	4' - 10"	4' - 5"
	3x12 or 2-2x12	9' - 5"	8' - 2"	7' - 3"	6' - 7"	6' - 7"	5' - 8"	5' - 4"
	4x6	6' - 2"	5' - 3"	4' - 8"	4' - 3"	3' - 11"	3' - 8"	3' - 5"
	4x8	8' - 2"	7' - 0"	6' - 3"	5' - 8"	5' - 3"	4' - 11"	4' - 7"
	4x10	9' - 8"	8' - 4"	7' - 5"	6' - 9"	6' - 3"	5' - 10"	5' - 5"
	4x12	11' - 2"	9' - 8"	8' - 7"	7' - 10"	7' - 3"	6' - 9"	6' - 4"
	3-2x6	7' - 1"	6' - 5"	5' - 9"	5' - 3"	4' - 10"	4' - 6"	4' - 3"
	3-2x8	9' - 5"	8' - 3"	7' - 4"	6' - 8"	6' - 2"	5' - 9"	5' - 5"
	3-2x10	11' - 9"	10' - 2"	9' - 1"	8' - 3"	7' - 7"	7' - 1"	6' - 8"
	3-2x12	13' - 8"	11' - 10"	10' - 6"	9' - 7"	8' - 10"	8' - 3"	7' - 10"

- Assumes 40 psf live load, 10 psf dead load, L/360 simple span beam deflection limit, cantilever length/180 deflection limit, No. 2 stress grade, and wet service conditions.
- Incising assumed for Douglas fir-larch, hem-fir, and spruce-pine-fir.
- Design values based on northern species with no incising assumed.
- Beam depth must be equal to or greater than joist depth if joist hangers are used

Figure 2. Beam Span Types

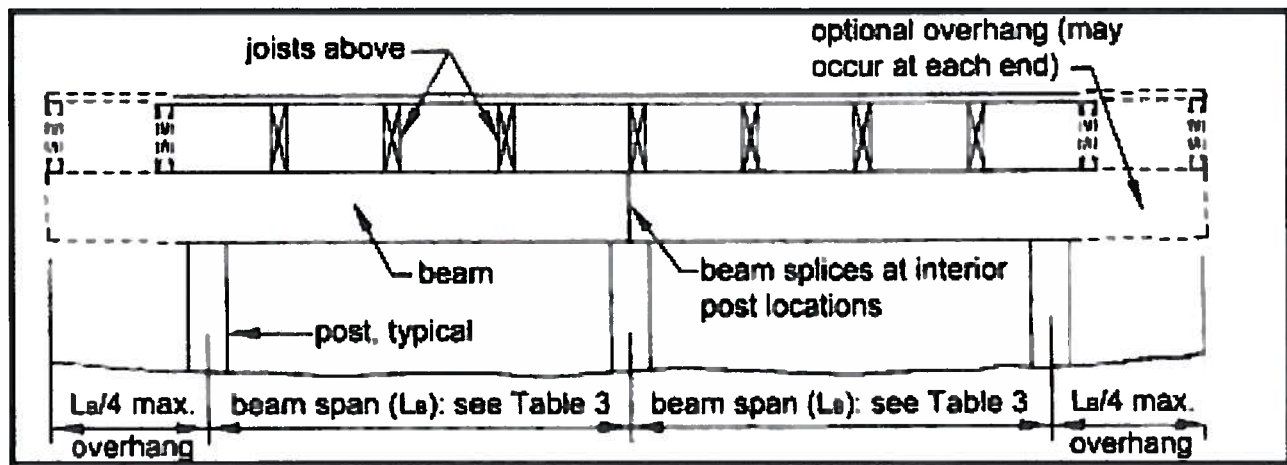

Post Requirements

IRC section R407.3 specifies a minimum 4x4 (nominal) wood column size however, it would often be overstressed in applications covered in this document. Requiring a minimum 6x6 post in DCA 6 is slightly conservative for most deck applications. Further, this simplification provides adequate bearing for beams.

Prohibiting attachment of the beam to the sides of the post with fasteners only ensures wood to wood bearing. Design of fasteners for wet-service conditions requires significant capacity reductions and should be evaluated by a design professional.

For 3-ply 2 inch nominal beams, a post cap is required since the remaining cross section at the post notch would not be sufficient to provide adequate connection of the beam to the column. The connector with extra corrosion protection and offers uplift and lateral load resistance.

Provisions for **Alternative Methods and Materials** allow for other post sizes and post-to-beam connections if approved by the Building Official. For example, in order to use a 4x4 post, a post cap connection would be required. There is not enough cross sectional area in a 4x4 to permit the let-in notch detail. Connector hardware for a 4x4 post is generally limited to support of 2-ply 2 inch nominal or 4 inch nominal beams. Certain post caps may be adjusted to fit a 3-ply 2 inch nominal member onto a 4x4 post, see Table 3.

Diagonal bracing can contribute to the stiffness of the deck and, therefore, cause additional lateral loads on the posts. Since center posts receive more vertical load than corner posts, additional lateral load can cause overstress. The lateral force applied to the corner posts is based on the capacity of the connection at the brace. Therefore, the full capacity of the brace connection is assumed to be developed and applied 2 feet below the beam.

Table 3. 4x4 Post Heights

Beam Span, L _B	Joist Span, L _J	Post Heights ¹				
		Southern Pine	Douglas Fir-Larch ³	Hem-Fir ³ , Western Cedars	Redwood	Ponderosa Pine, Red Pine, SPF ³
6'	<10'	4'	2'	3'	4'	3'
	<14'	3'	2'	2'	3'	2'
	<18'	2'	2'	2'	2'	2'
8'	<10'	3'	2'	2'	4'	2'
	<14'	2'	2'	2'	3'	2'
	<18'	2'	2'	2'	2'	2'
10'	<10'	3'	2'	2'	3'	2'
	<14'	2'	2'	2'	2'	2'
	<18'	2'	2'	2'	2'	2'
12'	<10'	2'	2'	2'	2'	2'
	<14'	2'	2'	2'	2'	2'
	<18'	2'	2'	2'	2'	2'
14'	<10'	2'	2'	2'	2'	2'
	<14'	2'	2'	2'	2'	2'
	<18'	2'	2'	2'	2'	NP
16'	<10'	2'	2'	2'	2'	2'
	<14'	2'	2'	2'	2'	2'
	<18'	2'	2'	2'	2'	NP
18'	<10'	2'	2'	2'	2'	2'
	<14'	2'	2'	2'	2'	NP
	<18'	2'	2'	NP	2'	NP

Table 4. Post Height for 6x6⁵ and Footing Sizes for all Posts

Beam Span, L _B	Post Heights ¹					
	Joist Span, L _J	Southern Pine	Douglas Fir-Larch ³	Hem-Fir ³ , Western Cedars	Redwood	Ponderosa Pine, Red Pine, SPF ³
6'	<10'	14'	14'	14'	14'	14'
	<14'	14'	14'	14'	14'	14'
	<18'	14'	14'	12'	14'	11'
8'	<10'	14'	14'	14'	14'	14'
	<14'	14'	14'	14'	14'	11'
	<18'	14'	13'	11'	12'	8'
10'	<10'	14'	14'	14'	14'	12'
	<14'	14'	13'	11'	13'	8'
	<18'	12'	11'	8'	11'	2'
12'	<10'	14'	14'	12'	14'	10'
	<14'	13'	12'	9'	11'	5'
	<18'	11'	9'	6'	9'	2'
14'	<10'	14'	13'	11'	13'	8'
	<14'	11'	10'	7'	10'	2'
	<18'	9'	8'	2'	8'	NP
16'	<10'	13'	12'	10'	12'	6'
	<14'	10'	9'	5'	9'	2'
	<18'	7'	5'	2'	7'	NP
18'	<10'	12'	11'	8'	11'	2'
	<14'	9'	8'	2'	8'	NP
	<18'	5'	2'	2'	6'	NP

1. Assumes 40 psf live load, 10 psf dead load, L_B/4 and L_J/4 overhangs, No 2 Stress grade and wet service conditions
2. Assumes 1,500 psf soil bearing capacity and 150 pcf concrete. Value may be multiplied by 0.9 for corner posts.
3. Incising assumed for Douglas fir-larch, hem-fir, and spruce-pine-fir.
4. Assuming 2,500 psi compressive strength of concrete. Coordinate footing thickness with post base and anchor requirements.
5. 8x8 nominal posts may be substituted anywhere in Table to a maximum of 14'.

Cast-in-place

These products are cast into the concrete at the time of the pour.

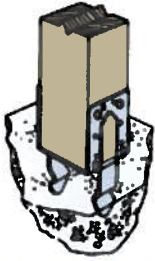

PB Post Base: For use with decay resistant or preservative-treated wood. ZMAX® or hot-dip galvanized coating recommended.

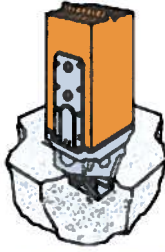

PBS Post Base with Standoff: Features a 1" standoff. ZMAX® or hot-dip galvanized coating recommended.

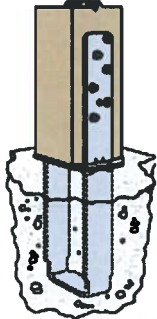

CBQ Column Base: Installs with SDS wood screws. Hot-dip galvanized coating recommended.

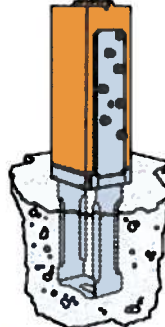

CBSQ Column Base: Installs with SDS wood screws and features a 1" standoff. Hot-dip galvanized coating recommended.

Post-installed

These products utilize anchor bolts installed during the pour or after the concrete hardens.

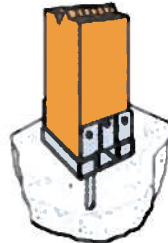

ABA Adjustable Post Base with Standoff: Offers adjustability to account for imperfect bolt placement as well as a 1" standoff. Available with a ZMAX® galvanized coating.

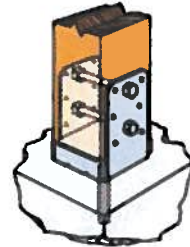

ABU Adjustable Post Base with Standoff: Offers adjustability, a 1" standoff and increased uplift loads. ZMAX® coating or stainless steel recommended.



EPB44PHDG Elevated Post Base: Installs with Epoxy-Tie® or Acrylic-Tie® adhesives, incorporates a 1" standoff and offers vertical adjustability of the post. Hot-dip galvanized coating recommended.

Post-installed Anchors

Installing a post base on hardened concrete requires the installation of a post-installed anchor to attach the base to the concrete. Simpson Strong-Tie offers a variety of mechanical anchors and anchoring adhesives that are code listed for structural applications.

Joists Bearing on a Beam

At the point where the joist bears on top of a beam, there must be a connection to resist lateral and uplift forces. Blocking or framing is also required to prevent overturning of the joists.

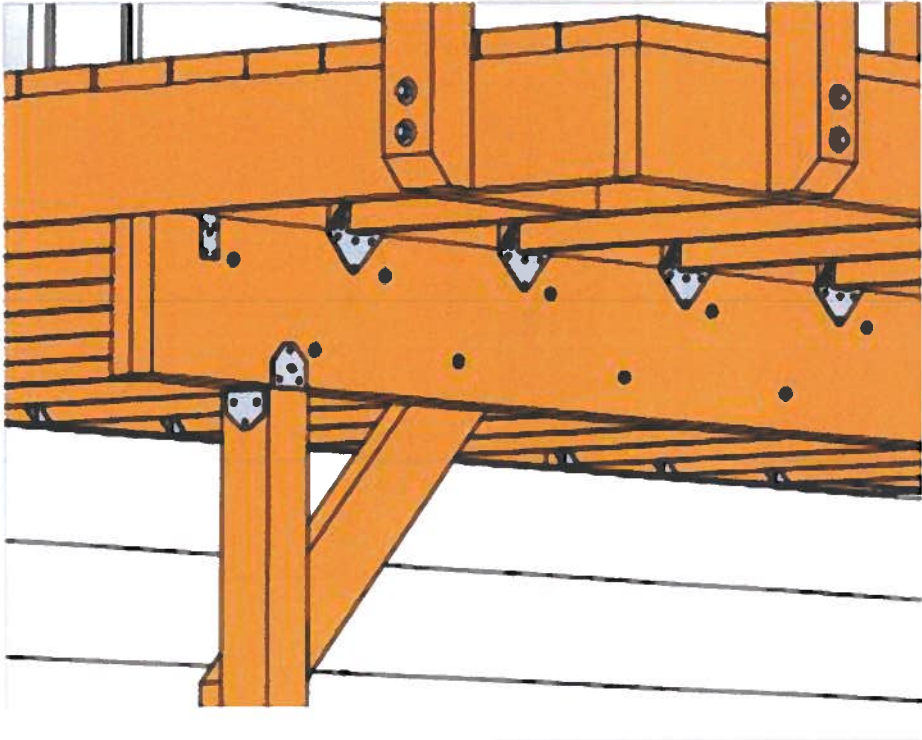

Simpson Strong-Tie® Solutions

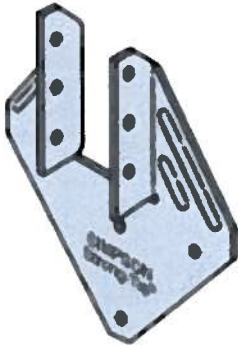

H1 Hurricane Tie: Holds joist on both sides. ZMAX® galvanized coating recommended.

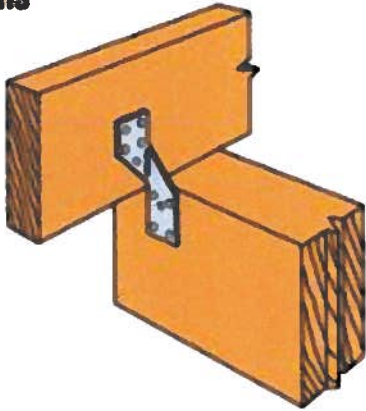

H2.5 Hurricane Tie: Suitable for single-sided applications. ZMAX® galvanized coating or stainless steel recommended.

Beam-to-Post Connections

At the point where a beam meets a post, it must be properly connected to the post in order to resist gravity, lateral and uplift loads. This pertains to solid sawn beams or those comprised of multiple members, whether they rest on top or are fastened to the side of the post.

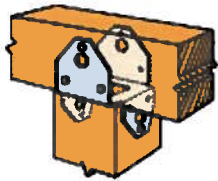
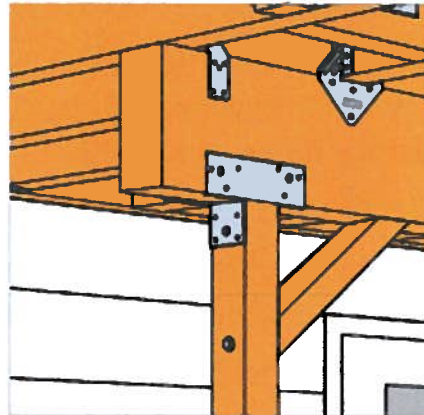
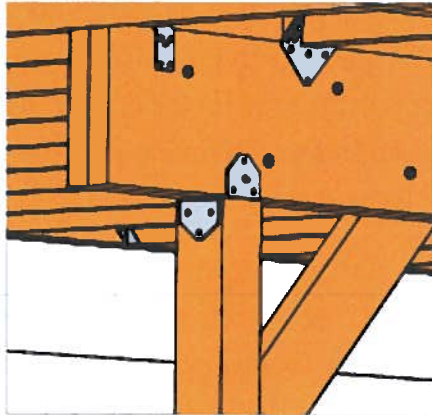

BC Post Cap: For single-member solid sawn beams. ZMAX® coating or stainless steel recommended.

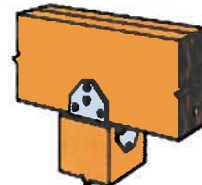

BCS Post Cap: Connects double 2x's to a 4x post or triple 2x's to a 6x post. ZMAX® coating or stainless steel recommended.

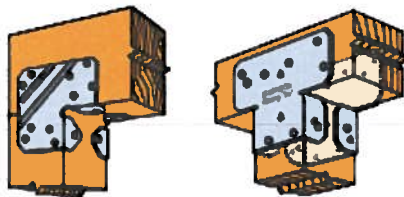

LCE/AC Retrofit Post Caps: Two-piece cap may be installed before or after lumber is in place when the sides of the post and beam are flush. ZMAX® coating or stainless steel recommended.

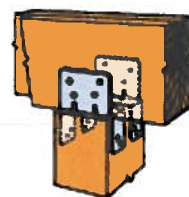

LPC Post Cap: Two-piece cap adjusts for beams smaller than post width. Features a ZMAX® galvanized coating.

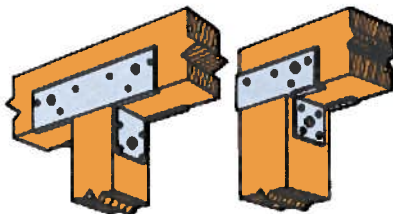

PC/EPC Post Caps: Connects beams at the top of the post. ZMAX® galvanized coating recommended.

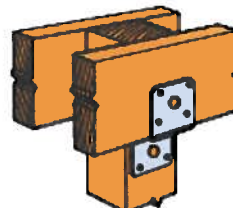

DJT14: Connects beams at the side of the post. ZMAX® coating or stainless steel recommended.

Ledger Attachment Requirements

General: Attach the ledger board, which shall be greater than or equal to the rim joist depth, to the existing exterior wall in accordance with **Figures 6-8**. When attachments are made to the existing house band joist, the band joist shall be capable of supporting the new deck. If this cannot be verified of conditions at the existing house differ from the details herein, then either a free-standing deck or full plan submission is required. Minimum deck ledger size is 2x8.

Siding and Flashing: House siding or the exterior finish system must be removed prior to installation of the ledger board. Approved corrosion resistant flashing is required at any ledger board connection to a wall of wood framed construction. See **Figure 6** for continuous flashing with drip edge. The threshold shall be carefully flashed and caulked to prevent water intrusion due to splash from the deck or melting snow and ice.

Manufactured Wood I-Joist: The term "I-Joist" denotes manufactured wood "I" joists (See **Figure 4**). Many new homes constructed with wood I-Joists include 1" or thicker engineered wood products such as oriented strand board or structural composite lumber including laminated veneer lumber- as band joists (or rim boards) that can support the attachment of a deck (See **Figure 6**). However, some older homes might be constructed with band boards that are too thin (less than 1") to support a deck. In such cases, a free-standing deck or a full plan submission is required.

Manufactured Wood Truss: A metal plate connected wood truss (MPCWT) is an engineered prefabricated structural component designed for each specific application. MPCWT's used in residential floors are often installed with 2x4 lumber "ribbon" at the ends of the trusses (See **Figure 5**) to tie the ends of the trusses together. The ribbon board, by itself, is not intended to support the deck ledger and deck. Installations using MPCWT require a standard detail provided by the truss designer, a free-standing deck, or a full plan submission.

Figure 4

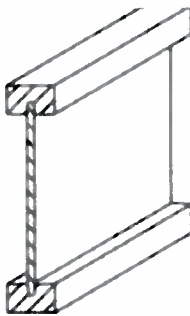

Figure 5

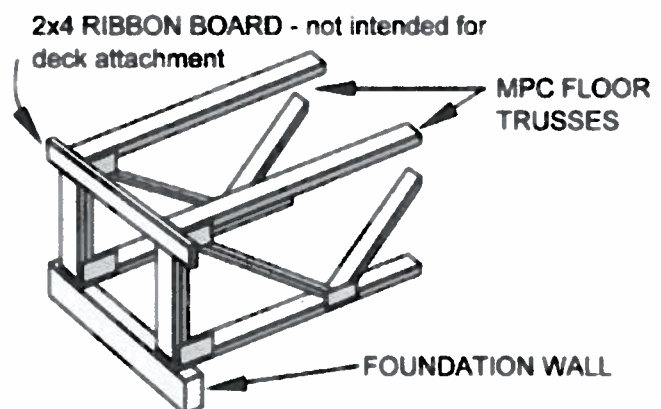

Figure 6

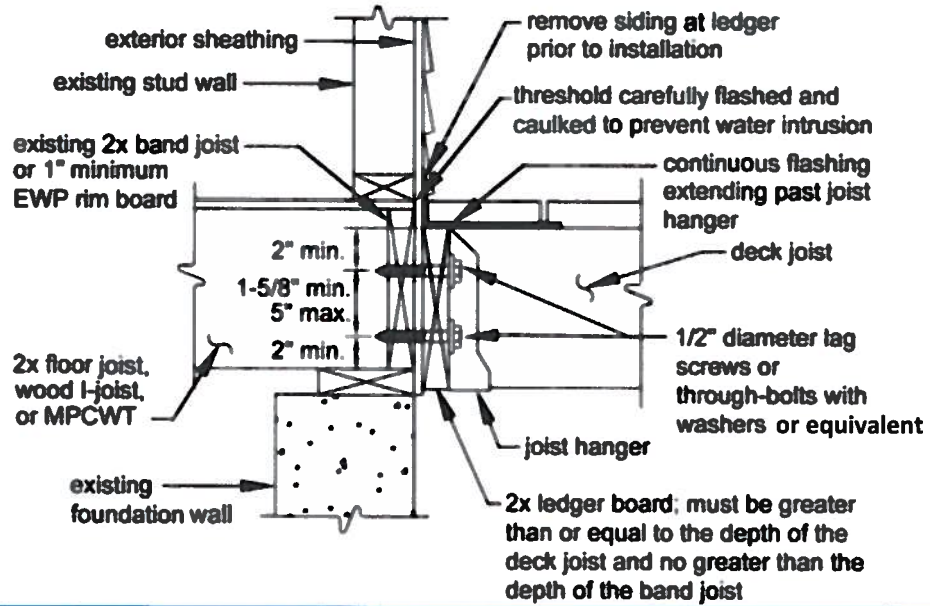
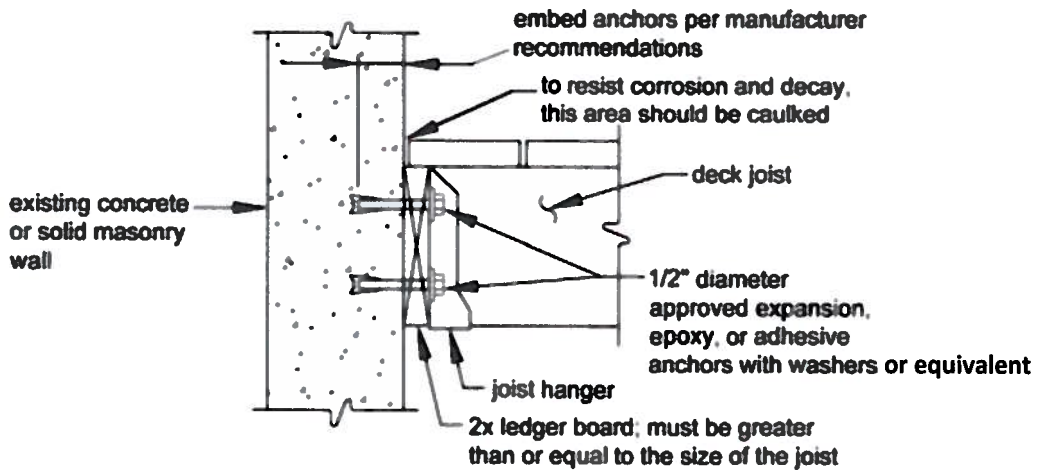
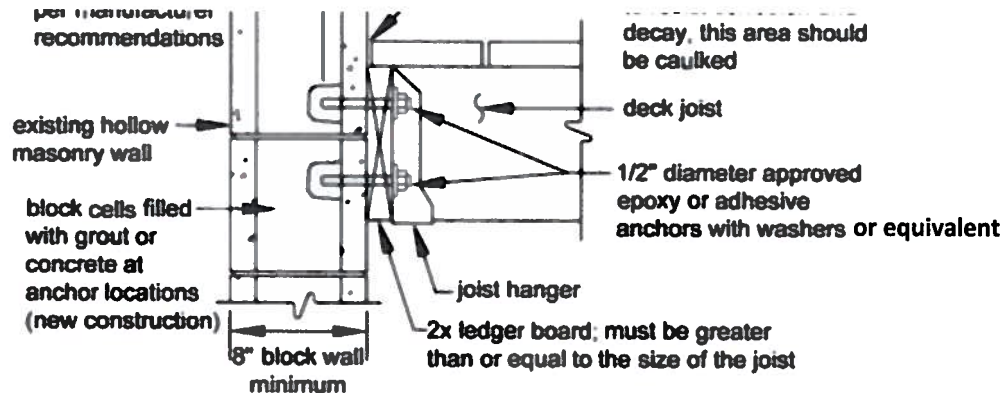

Figure 7



Attachment of Ledger Board to Foundation Wall (Hollow Masonry)

Figure 8



Prohibited Ledger Attachments

Attachments to exterior veneers (brick, masonry, stone) and to cantilevered floor overhangs or bay windows are prohibited. (See [Figure 9-10](#)). In such cases the deck shall be free-standing.

Figure 9

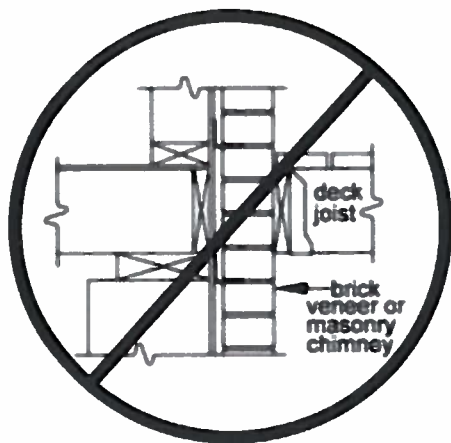

Figure 10



Table 5

Fastener Spacing for a Southern Pine, Douglas Fir-Larch, or Hem-Fir Deck Ledger or Band or Rim Joist and a 2-inch Nominal Solid-Sawn Spruce-Pine-Fir Band Joist or EWP Rim Joist. ^{3.4.3.4.8}
(Deck Live Load = 40 psf, Deck Dead Load = 10 psf)

Joist Span	Rim Joist Or Band Joist	6'-0"	6'-1"	8'-1"	10'-1"	12'-1"	14'-1"	16'-1"
		and less	to 8'-0"	to 10'-0"	to 12'-0"	to 14'-0"	to 16'-0"	to 18'-0"
Connection Details		On-Center Spacing of Fasteners						
½" diameter lag screw ¹ with 15/32" maximum sheathing	1" EWP	24"	18"	14"	12"	10"	9"	8"
	1-1/8" EWP	28"	21"	16"	14"	12"	10"	9"
	1-1/2" Lumber	30"	23"	18"	15"	13"	11"	10"
½" diameter bolt with 15/32" maximum sheathing	1" EWP	24"	18"	14"	12"	10"	9"	8"
	1-1/8" EWP	28"	21"	16"	14"	12"	10"	9"
	1-1/2" Lumber	36"	36"	34"	29"	24"	21"	19"
½" diameter bolt with 15/32" maximum sheathing and ½" stacked washers ^{2,7}	1-1/2" Lumber	36"	36"	29"	24"	21"	18"	16"

1. The tip of the lag screw shall fully extend beyond the inside face of the band or rim joist.
2. The maximum gap between the face of the ledger board and face of the wall sheathing shall be ½".
3. Ledgers shall be flashed or caulked to prevent water from contacting the house band joist (See [Figures 6 and 7](#)).
4. Lag screws and bolts shall be staggered per [Figure 11](#).
5. Deck ledgers shall be minimum 2x8 pressure-preservative-treated No. 2 grade lumber, or other approved materials as established by standard engineering practice.
6. When solid-sawn pressure-preservative-treated deck ledgers are attached to engineered wood products (minimum 1" thick wood structural panel band joists or structural composite lumber including laminated veneer lumber), the ledger attachment shall be designed in accordance with accepted engineering practice. Tabulated values based on 300 lbs. and 350 lbs. for 1" and 1-1/8" EWP rim joist, respectively.
7. Wood structural panel sheathing, gypsum board sheathing, or foam sheathing, but are not permitted in combination with gypsum board or foam.
8. Fastener spacing also applies to southern pine, Douglas fir-larch, and hem-fir band or rim joists.

Ledger Board Fasteners

Only those fasteners noted below are permitted **LEAD ANCHORS ARE PROHIBITED.**

Deck ledger connection to band joist or rim board.

The connection between a deck ledger and a 2-inch nominal lumber band joist (1- 1/2" actual) or EWP rim board bearing on a sill plate or wall plate shall be constructed with 1/2" lag screws or bolts with washers per **Table 5** and **Figure 11**.

Placement of lag screw or bolts in deck ledgers

The lag screws or bolts shall be placed as shown in **Figure 11**. The lag screws or bolts shall be staggered from the top to the bottom along the horizontal run of the deck ledger (See **Figure 11**). Proper installation of lag screws or bolts shall be verified by the authority having jurisdiction.

Figure 11

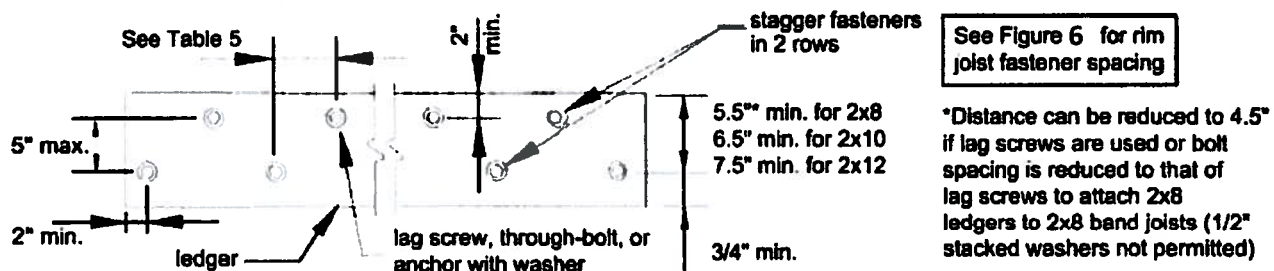

Through-Bolts

Through-bolts shall have a diameter of 1/2". Pilot holes for through-bolts shall be 17/32" to 9/16" in diameter. Through-bolts require washer at the bolt head and nut.

Expansion and Adhesive Anchors

Use approved expansion or adhesive anchors when attaching a ledger board to a concrete or solid masonry wall as show in **Figure 8**. Expansion and adhesive anchor bolts shall have a diameter of 1/2". Minimum spacing and embedment length shall be per the manufacturer's recommendations. All anchors must have washers.

Lag Screws

Lag screws shall have a diameter of 1/2". Lag screws may be used only when the field conditions conform to those shown in **Figure 6**. See **Figure 12** for lag screws length and shank requirements. All lag screws shall be installed with washers.

Lag Screw installation requirements: Each Lag screw shall have pilot holes drilled as follows:

1. Drill a 1/2" diameter hole in the ledger board.
2. Drill a 5/16" diameter hold into the band board of the house.

DO NOT DRILL A 1/2" DIAMETER HOLE INTO THE BAND BOARD.

The threaded portion of the lag screw shall be inserted into the pilot hole by turning. **DO NOT DRIVE LAG SCREWS WITH A HAMMER.** Use soap or a wood compatible lubricant as required to facilitate tightening. Each lag screw shall be thoroughly tightened (snug but not over-tightened to avoid wood damage).

Figure 12

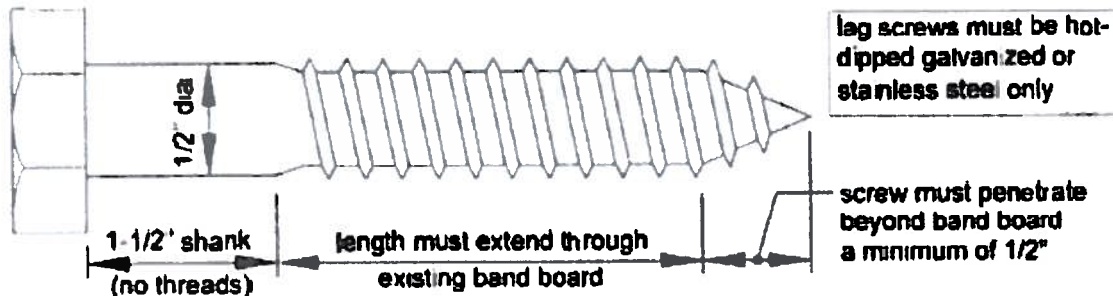

Bracing Methods

All decks with post heights greater than 2.5 feet are required to be designed to resist lateral load caused by human activity and environmental forces. Use **Table 6** to determine the applicable methods based on post height and deck type.

Table 6

Post Height (feet) Less than or equal to:	Single Span Decks	Multi-span Decks	Free-standing Decks
2.5	None Required	None Required	None Required
11	<ul style="list-style-type: none"> ➤ Method 1 or ➤ Method 2 	<ul style="list-style-type: none"> ➤ Method 2¹ 	<ul style="list-style-type: none"> ➤ Method 2¹ and ➤ Method 3
14	<ul style="list-style-type: none"> ➤ Method 1 and ➤ Method 2 	<ul style="list-style-type: none"> ➤ Method 1 and ➤ Method 2 	<ul style="list-style-type: none"> ➤ Method 1, ➤ Method 2 and ➤ Method 3

Method 2 may be omitted from the beam closest to the existing house wall if Method 1 is utilized at the house connection

Method-1, Tension-ties (four total):

- Install one tension-tie at each end joist and install the remaining two to inside joists equally spaced along the width of the deck as shown in **Figure 13**. A set of tension-ties shall be installed for each structurally independent section of deck.
- Tension-ties shall be attached to the joists and exterior wall per the manufacturer's instructions with specified fasteners as shown in **Figure 14**. Fasteners shall penetrate a minimum of 3 inches into the sill plate or top plate of wood framed wall.

- Approved tension-ties are listed in **Table 7**. The minimum capacity of each tension-tie shall be 750 pounds.
- Where attaching to a concrete or solid masonry wall, fasteners are permitted to be substituted with expansion anchors or adhesive anchors with a threaded rod as recommended by the tension-tie manufacturer. The withdrawal capacity of the anchors shall be a minimum of 750 pounds. The anchor shall be installed per its manufacturer recommendations.

Figure 13

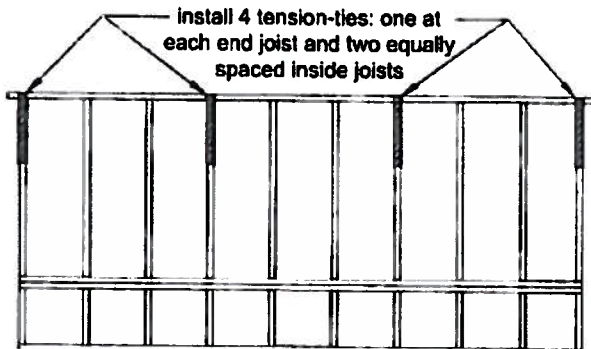
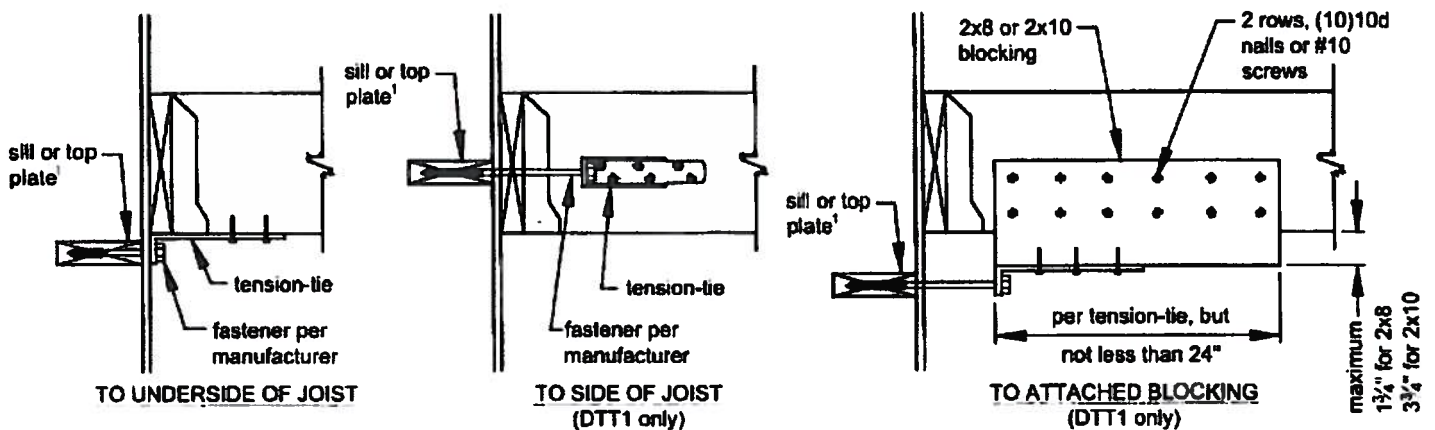

Table 7

Manufacturer	Product
Simpson Strong - Tie	DTT1
USP	LTS19
USP	ADTT-TZ

Figure 14



¹ Tension-ties may be anchored to concrete or solid masonry walls with expansion or adhesive anchors as permitted on Page 15

Method-2, Knee-bracing at beam:

- Knee-bracing shall be comprised of 2x or 6x6 members.
- Decks shall have 2x knee-bracing installed at each post-beam location of 6x6 knee-bracing at end posts and both sides of every other interior post in accordance with **Figure 15**.
- Connections of knee-bracing shall be in accordance with **Figure 17 or 18**.

Figure 15

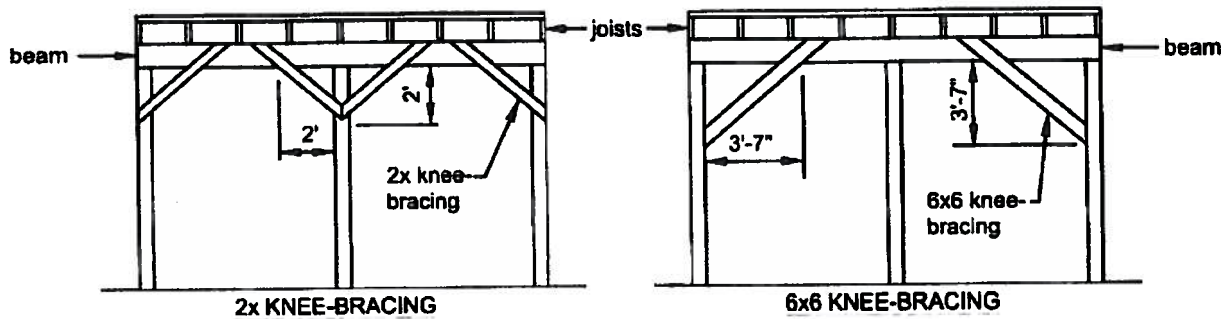

Method-3, Knee-bracing at joists-post locations (Free-Standing Decks Only):

- Knee-bracing shall be comprised of 2x or 6x6 members.
- Knee-bracing shall be installed at each post-joist location in accordance with **Figure 16**.
- Connections of knee-bracing shall be in accordance with **Figure 17 or 18**.

Figure 16

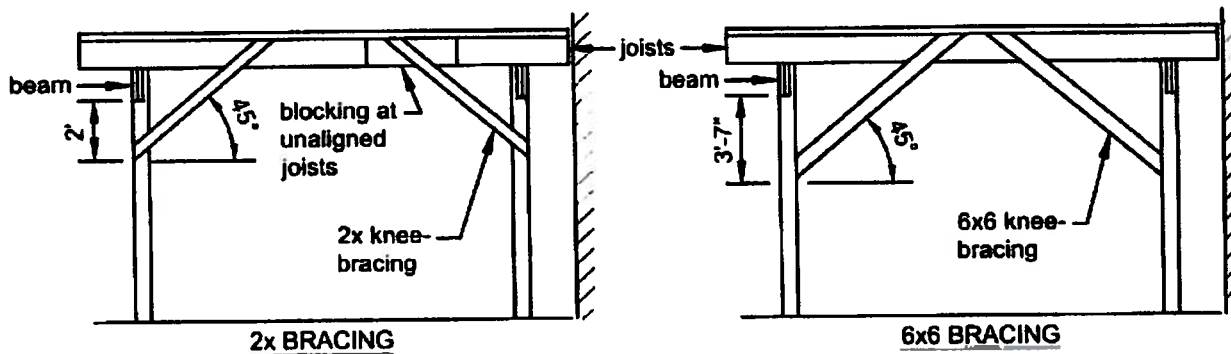
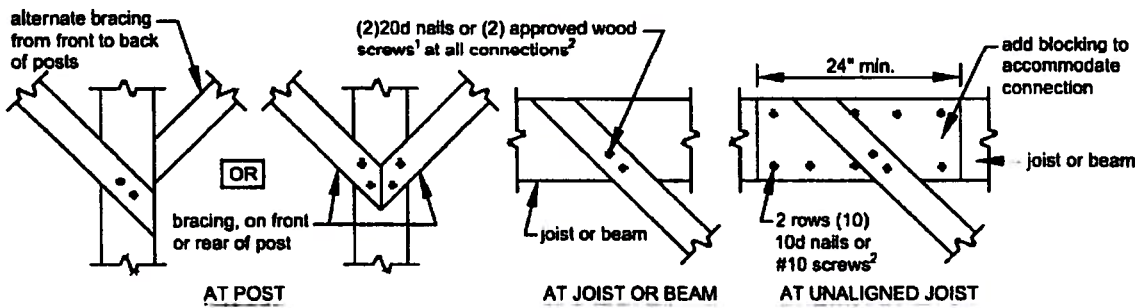
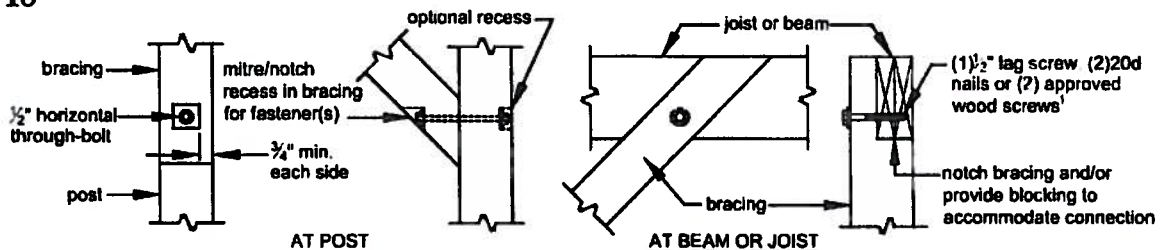

Figure 17



Nails shall have a distance of 3/4 inches to all edges and 1/2 inches to ends of the bracing member.

Figure 18



Guards

Guard Construction

A guard is required when a deck is greater than 30 inches above grade at a point 36 inches from the edge of the deck, as shown in **Figure 19**. Guards shall be constructed in accordance with the requirements herein; deviations are prohibited. Guards which are not required, but are nevertheless provided, must also comply with these requirements.

Plastic Composites

Plastic composites of equal dimension and may be substituted for guard cap and infill elements shown in **Figure 20** provided the manufacturer's performance criteria specifically permit such use.

Figure 19

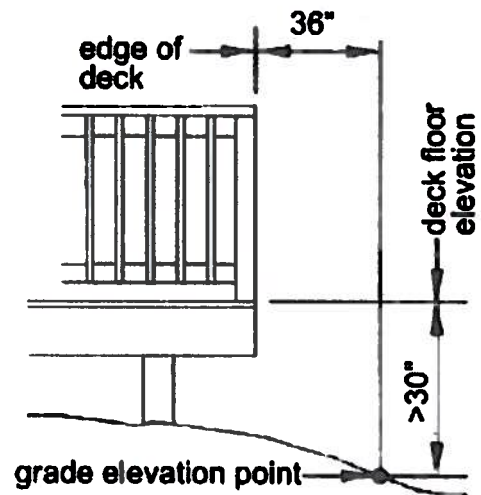

Guard Systems

Guard systems with a valid evaluation report from an accredited listing agency are permitted. Pre-fabricated systems without an evaluation report will require a plan review during the permit application process.

Openings

Guard shall be constructed to restrict the passage of a 4-inch diameter sphere through any opening. Wet lumber shall be spaced such that when shrinkage occurs, a compliant opening is maintained.

Figure 20

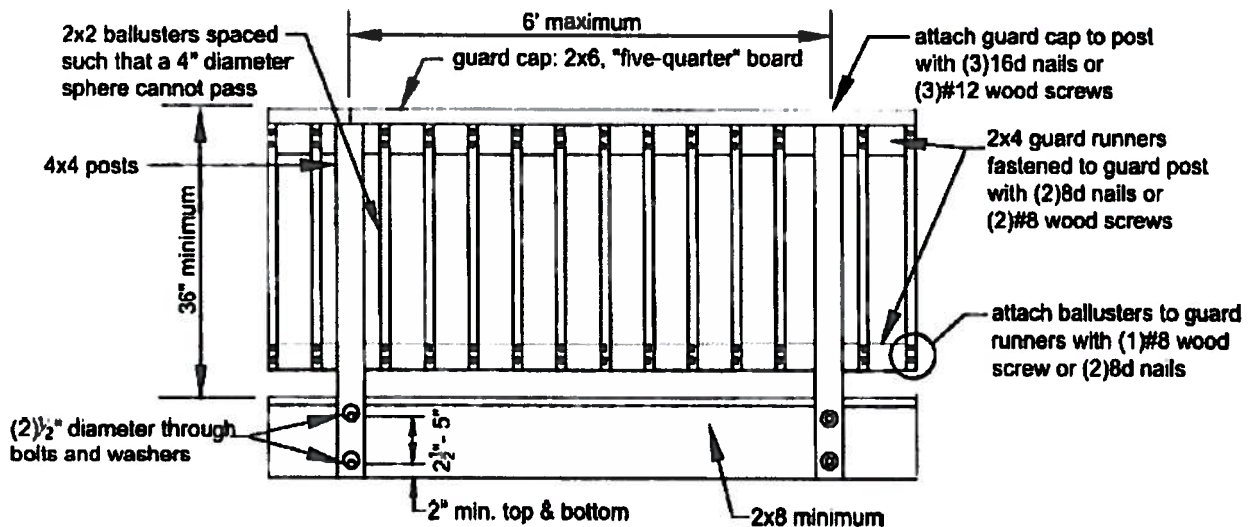

Guard Post Connection

Guard posts shall be attached to the deck structure in accordance with the requirements below in order to ensure resistance to imposed loads.

- Notching guard posts, as shown in **Figure 21**, is prohibited.
- Hold-down anchors, as shown in **Figure 22 and 23**, shall be used to attach the guard post to the end joist and rim joist, respectively.
- Hold-down anchors shall have a minimum capacity of 1,800 pounds.
- Guards may be attached to either side of the rim joist or end joist.

Figure 21



Figure 22

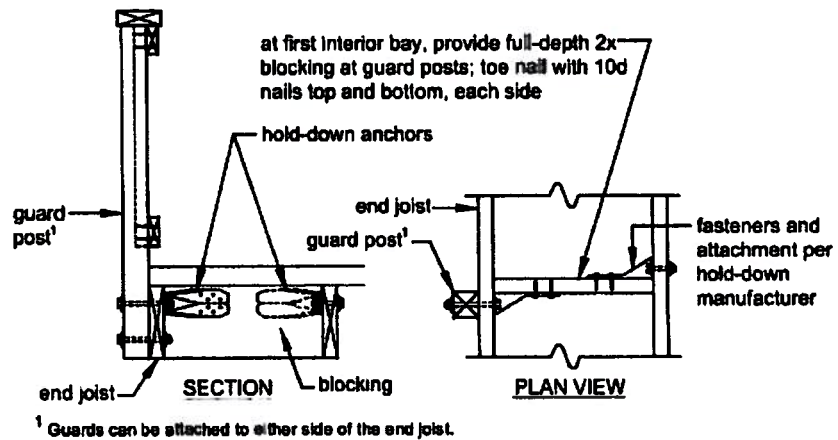
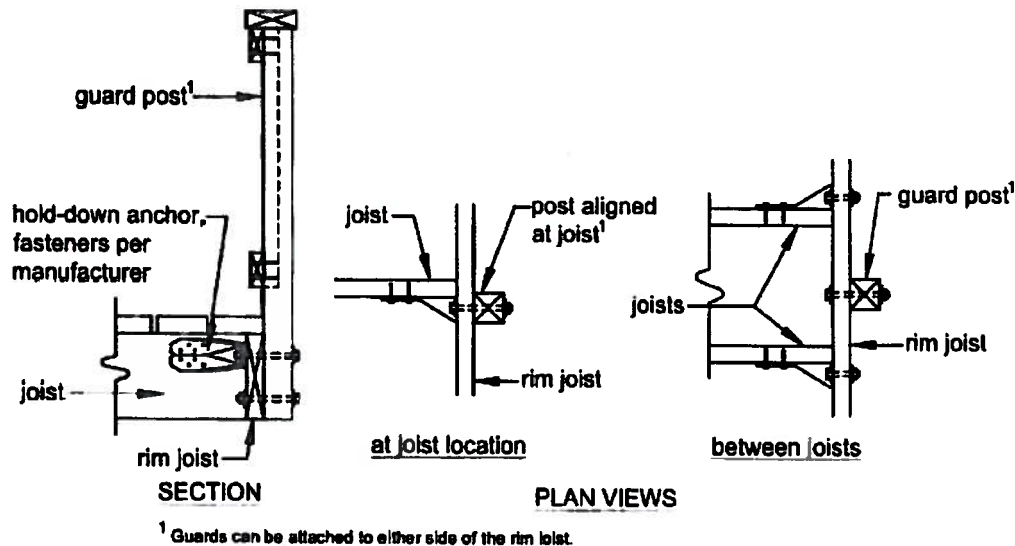

Figure 23



Stairs

Stair Geometry

Stairs shall be constructed with the dimensions listed below.

- The minimum width of a stairway is 36 inches.
- Stair geometry and opening limitations shall meet the requirements show in **Figure 24**. Treads, risers, and nosing dimensions shall not deviate at each step by more than 3/8 inches.

Figure 24

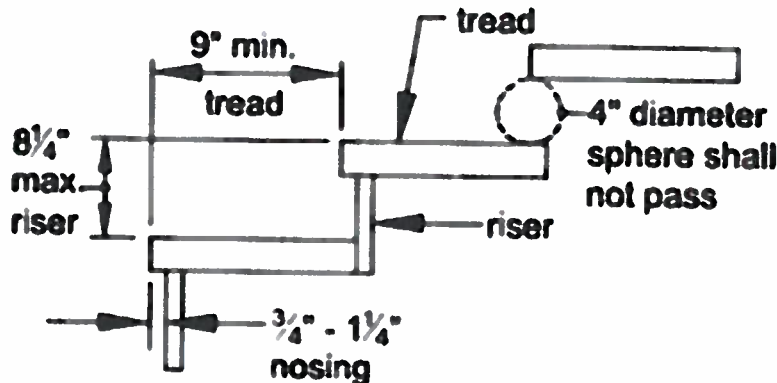

Stair Landing

- If the total vertical height of a stairway exceeds 12 feet, then an intermediate landing is required and must be constructed as a free-standing deck.
- Stair landings may be constructed with 4x4 posts with post heights no greater than 8 feet.
- Landing widths shall be equal to the total width(s) of the stairway(s) served.

Stair Construction

Stair Stringers:

- Stringers shall be sawn or solid 2x12s complying with the tread and riser geometry requirements.
- Stringers shall be spaced at a maximum of 18 inches on center.
- Stringers shall bear on footings and attach to the deck or landing per **Figure 25**.
- Stringer span length is measured using the horizontally projected distance between the bearing at each end and shall not exceed the dimensions show in **Figure 26**.
Solid Stringer Exception: Solid stringers of stairways with a width equal to 36 inches shall be permitted to have a span as shown in **Figure 26**.
- Throat size of cut stringers shall not exceed the value shown in **Figure 26**.

Figure 25

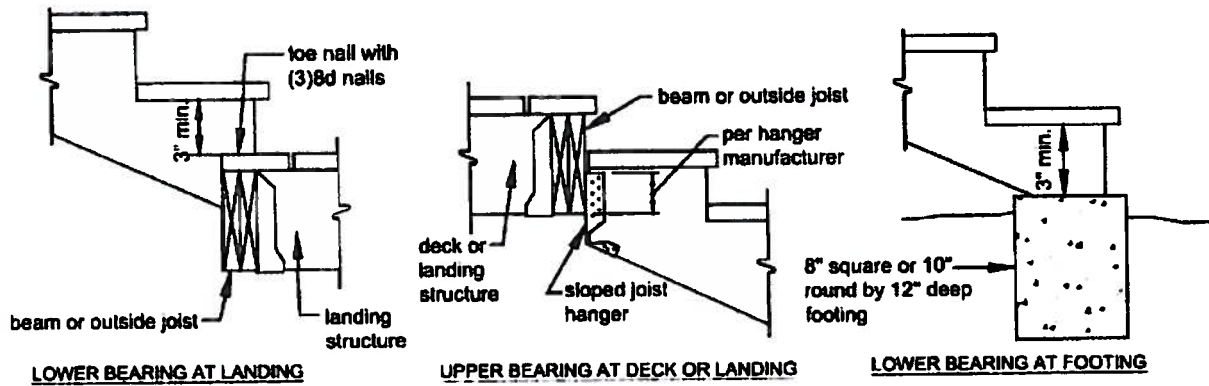
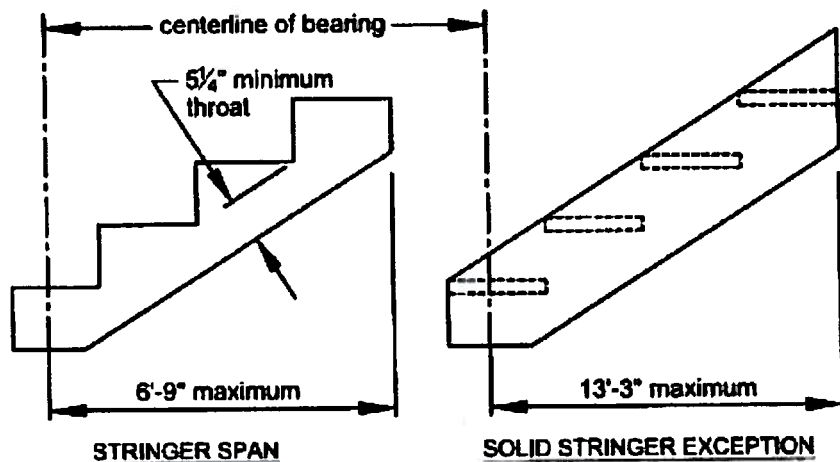

Figure 26



Tread and riser material:

- Tread material shall be equivalent to the decking in accordance with **Figure 27**. The span of plastic composites shall be per manufacturer and in some cases may be less than 18 inches specified in **Figure 27**.
- Stairs constructed using the solid stringer exception shall have treads constructed 2x wood material only; see **Figure 27**.
- Risers may be framed with 1x lumber minimum or equivalent plastic composite. Open risers are permitted provided the opening does not allow the passage of a 4-inch diameter sphere.

Figure 27

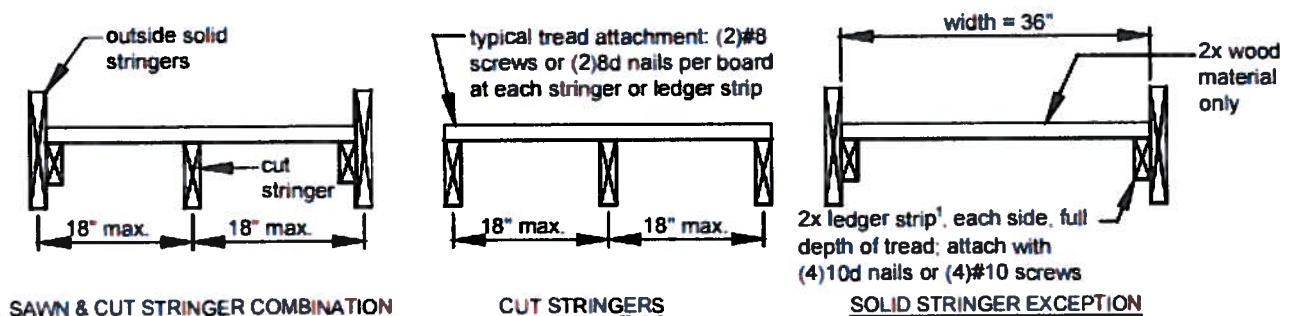

¹ A galvanized staircase clip angle, installed per manufacturer's instructions, is permitted to substitute for the 2x ledger strip.

Stair guards

Stair guards are required when the total rise of the stair is greater than 30 inches at a point 36 inches from the edge of the stair. Stair guards shall be constructed in accordance with **Figure 28**.

Figure 28

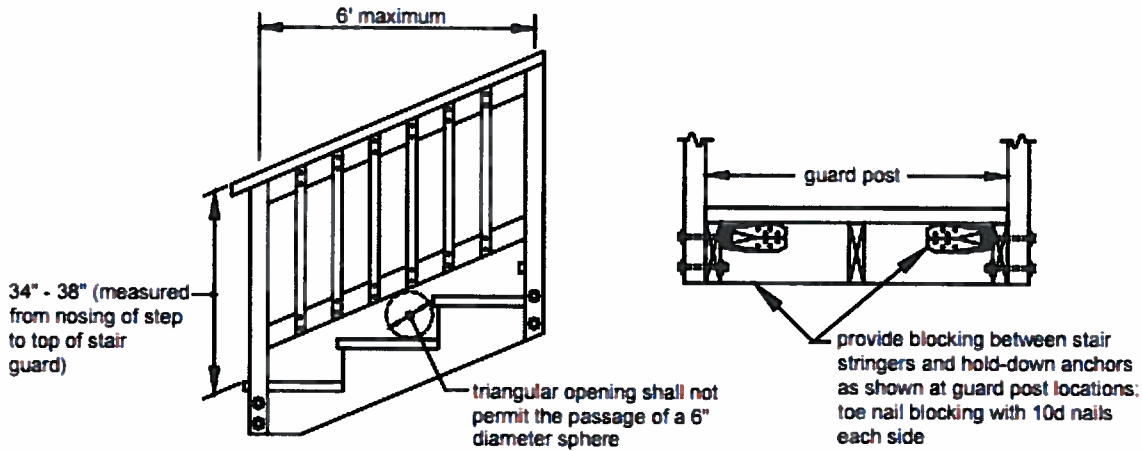

Handrails

- Stairs with four or more risers shall have a handrail on one side at a height between 34 to 38 inches above the nosing of the step.
- Handrails shall be attached to a stair guard or exterior wall acting as a barrier as shown in **Figure 29**.
- Handrail and connecting hardware material shall be decay and corrosion resistant.
- Handrails shall have a smooth surface with no sharp corners and shall be graspable. Recessed sections may be shaped from 2x6 or five-quarter as shown in **Figure 30**.
- Handrails shall run continuously from a point directly over the lowest riser to a point directly over the highest riser and shall return to the guard or wall at each end.
- Handrails may be interrupted by guard posts at a turn in the stair only.
- Handrails installed in lieu of window safety glazing, as required, shall be supported at appropriate intervals to ensure that when a 50-pound load is applied the rail does not deflect into the glass.

Figure 29

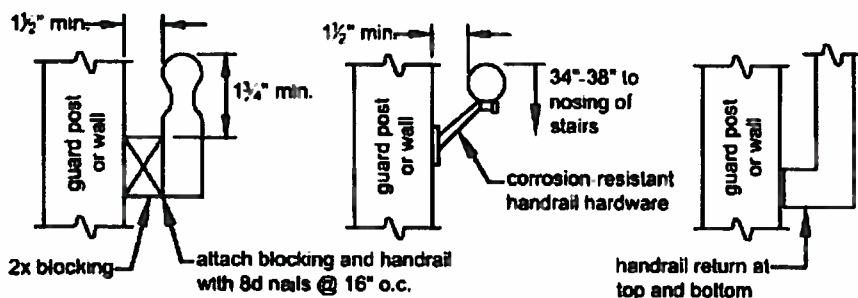
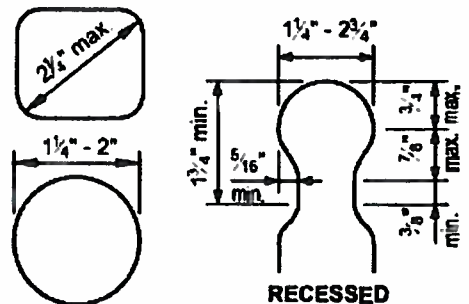

Figure 30



Safety Glazing

To reduce injury due to an accidental impact, safety glazing in window glass is required when the existing house wall encloses any portion of the deck surface or acts as a barrier to stairs, landings and areas at the top and bottom of the stairs.

Windows adjacent to deck surface

As shown in **Figure 31**, single panes of glass meeting all the requirements listed below must be safety-glazed.

- Glass area is greater than 9 sq. ft.
- The bottom edge of the pane is less than 18 inches above the walking surface of the deck, and
- The top edge of the pane is greater than 36 inches above the walking surface of the deck.

In the absence of safety glazing, a horizontal rail across the window must be installed. The rail must meet the requirements of a stair handrail *Page 22*.

Windows adjacent to stairways and landings

Single panes, partially or wholly located in the hatched area shown in **Figure 31**, must be safety-glazed. In the absence of safety glazing, a stair guard per *Page 21-22* or handrail per *Page 22*, must be constructed to separate the window from the stairway.

Figure 31

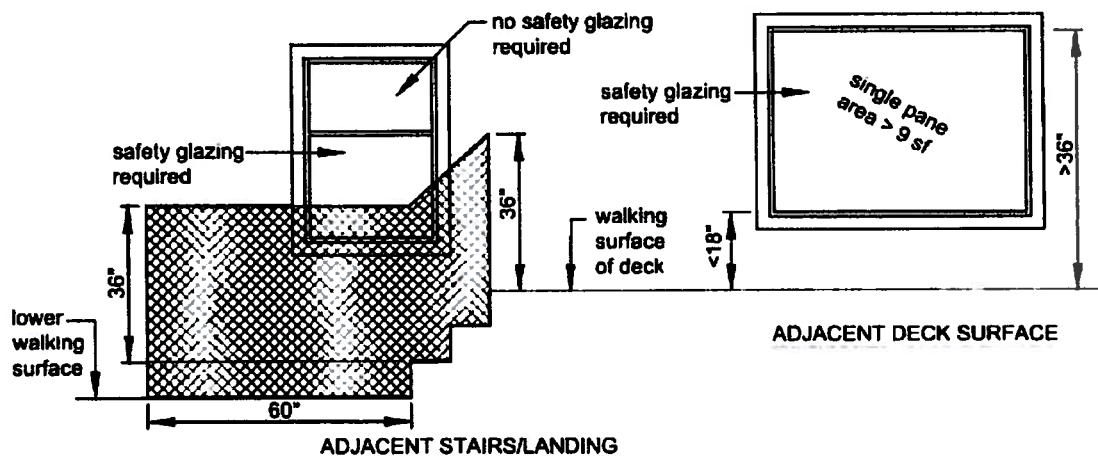

Electrical

Outlets: Decks shall have a minimum of one electrical outlet along the perimeter of the deck and within 6.5 feet of the floor.

Stair lighting: Each stairway section shall have a light source that illuminates all stairs and landings. Lights shall be operated from interior switches, motion detectors or timed switches. Low voltage lighting at each stair tread is permissible.

**May is
Deck Safety Month™**
A NADRA DECK SAFETY
PROGRAM— An effort to save
lives, and prevent injuries.

Check Your Deck™
Protect your family and friends



www.nadra.org
888.nadra.4u
(888.623.7248)

CONSUMER CHECKLIST

Split or decaying wood:

-Check several different areas of the deck to be sure the wood is still sound. This includes the ledger board (where the deck attaches to the house and a common source of deck failure), support posts and joists under the deck (if you can reach them), deck boards, railings and stairs.

-Pay special attention to any areas that tend to remain damp, are regularly exposed to water, or are in contact with fasteners.

Use a tool like an ice pick or a screwdriver to penetrate the wood surface. - If you can easily penetrate ¼ – ½ inch, break off a sliver of wood without splinters, or the wood is soft and spongy, decay may be present.

-This is also a good time to look for small holes in the wood, which may indicate insects.

Flashing:

-Flashing is a metal or plastic guard that directs water out and away from sensitive areas. It's often installed where the deck and house come together, keeping moisture and debris from collecting between the house and the deck's ledger board. Be certain the flashing is sound and firmly in place. Consider adding or replacing flashing if you notice areas that are obviously allowing water to collect.

Loose or corroded fasteners:

-Fasteners include nails, screws or anchors in the ledger board. Tighten any loose fasteners, and pound in any nails that have popped up. (Note: The ledger board should not be fastened with only nails.)

-If a fastener appears rusted or corroded, consider replacing it. A corroded fastener can cause deterioration in surrounding wood.

-The deck or stairs should appear even without sagging and should not sway or move when tested.

Railings and banisters:

-These should be secure. Push on them to be sure there is no give.

-Also, check to be sure they are high enough (most codes require a 36" high railing and usually encourage 42" high railings) with rails no more than 4" inches apart (measured from the inside of the rails) to keep small children and pets from squeezing through. This is especially important the higher your deck is off the ground.

Stairs:

-Check any railings or handrails to be sure they are firmly held in place; check also the risers and stringers to be certain they are securely attached and not decayed.

-If the area behind the stair treads is open, this opening should be no more than 4" high.

-Also, always keep stair pathways clear of planters, décor, toys and other items that can present a tripping hazard.

Cleaning and maintenance:

-Clean away any leaves and debris, since these can be slippery and promote mildew.

-If mildew is present or the deck coating has worn away, make time to clean and apply a new waterproofing coating. It can help prevent the split, decayed wood and loosened fasteners mentioned earlier.

Grills, fire pits, chimneys, heaters and candles:

-These features can create a warm and cozy deck atmosphere, but make sure any source of fire or heat is safely placed away from flammable surfaces or that the deck surface is protected by a non-flammable pad.

-Always use caution and follow manufacturers' directions.

Lighting and electrical:

-Be sure all lighting is working; clean any light covers to allow maximum light to shine through, and trim any plants or tree limbs that may be blocking light.

-If you don't have adequate lighting, there are a lot of great new deck lighting products you could consider to illuminate your steps and pathways.

-Be sure all electrical outlets, appliances and features are up to code, in good condition, and childproof if children are present.

-Watch that any electrical cords do not present a tripping hazard.

Outdoor Furniture and Storage:

-Test all outdoor furniture to be sure it is sturdy. Avoid placing seating right at the edge of the deck. If you have a swing or hammock installed, test the chains and ropes to be sure they are secure. Consider installing childproof latches on any storage boxes and benches.

-Be sure to keep all deck related chemical products stored safely away from children, including BBQ lighter fluids, matches, cleaners, etc.

Surrounding trees:

If you have trees overhanging your deck, make certain there is no danger of decaying limbs breaking free and falling from trees surrounding the deck.



Photo courtesy of DeckLok Bracket Systems.

Protect your family and friends.
Get a once-a-year deck inspection by a qualified professional.

The North American Deck and Railing Association (NADRA) promotes outdoor living at its best, in safe and creative environments for the enjoyment of every homeowner.

